



US006617608B2

(12) **United States Patent**
Bae et al.

(10) **Patent No.:** **US 6,617,608 B2**
(45) **Date of Patent:** ***Sep. 9, 2003**

(54) **ELECTRO-LUMINESCENT DISPLAY AND A METHOD OF MANUFACTURING THE SAME**

(75) Inventors: **Sung-Joon Bae**, Sungnam-shi (KR);
Jae-Yong Park, Seoul (KR)

(73) Assignee: **LG. Philips LCD Co., Ltd.**, Seoul (KR)

(*) Notice: This patent issued on a continued prosecution application filed under 37 CFR 1.53(d), and is subject to the twenty year patent term provisions of 35 U.S.C. 154(a)(2).

Subject to any disclaimer, the term of this patent is extended or adjusted under 35 U.S.C. 154(b) by 0 days.

(21) Appl. No.: **09/550,411**

(22) Filed: **Apr. 17, 2000**

(65) **Prior Publication Data**

US 2003/0062523 A1 Apr. 3, 2003

(30) **Foreign Application Priority Data**

May 27, 1999 (KR) 99-19286

(51) **Int. Cl.⁷** **H01L 35/24**

(52) **U.S. Cl.** **257/40; 257/72; 257/59; 257/83; 257/99**

(58) **Field of Search** 315/169.3; 345/76; 257/79, 642, 759, 40, 59, 72, 83, 99; 438/82, 99, 623

(56) **References Cited**

U.S. PATENT DOCUMENTS

5,550,066 A 8/1996 Tang et al.

5,670,792 A	*	9/1997	Utsugi et al.	257/59
5,684,365 A	*	11/1997	Tang et al.	315/169.3
6,046,547 A	*	4/2000	Nishio et al.	315/169.3
6,175,345 B1	*	1/2001	Kuribayashi et al.	345/76
6,194,837 B1	*	2/2001	Ozawa	315/169.1
6,204,610 B1	*	3/2001	Komiya	315/169.3
6,236,063 B1	*	5/2001	Yamazaki et al.	257/59
6,246,179 B1	*	6/2001	Yamada	315/169.3

FOREIGN PATENT DOCUMENTS

JP 08227276 * 9/1996

* cited by examiner

Primary Examiner—Eddie Lee

Assistant Examiner—Eugene Lee

(74) *Attorney, Agent, or Firm*—Birch, Stewart, Kolasch & Birch, LLP

(57) **ABSTRACT**

An electro-luminescent display and a method of manufacturing thereof prevents the formation of a barrier interface between the anode electrode and the electro-luminescent layer by placing the electro-luminescent layer directly on the anode electrode so that there is no need to etch a subsidiary layer so that the electro-luminescent layer and the anode electrode have excellent electrical contact. The elimination of this etching step prevents damage to the anode electrode caused by collision of ions with the anode electrode during the etching process. Further, etch remainders or contaminant particles that exist in the etchant gas are prevented from accumulating on the anode electrode. Thus, the charge carriers of the anode are easily transported across the interface between the anode electrode and the electro-luminescent layer so as to greatly improve the expected life span, the brightness, and the efficiency of the electro-luminescent display.

27 Claims, 6 Drawing Sheets

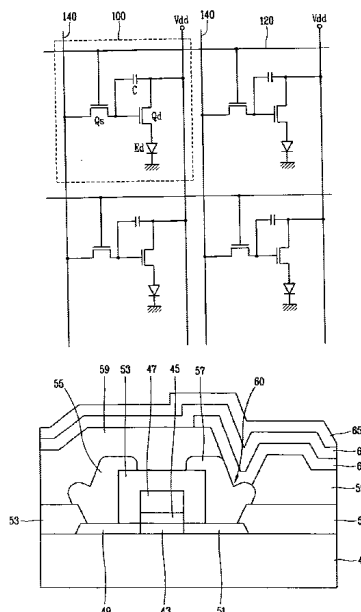

FIG. 1A
RELATED ART

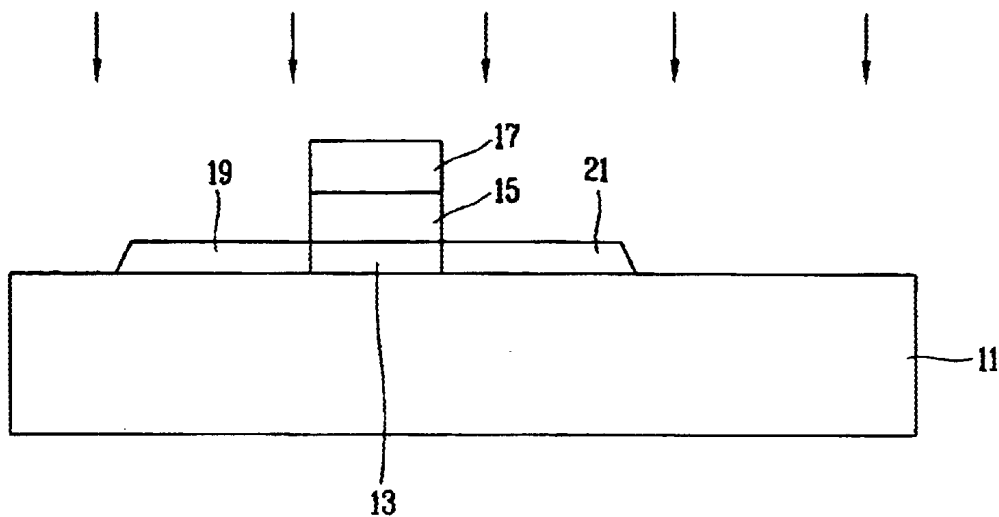

FIG. 1B
RELATED ART

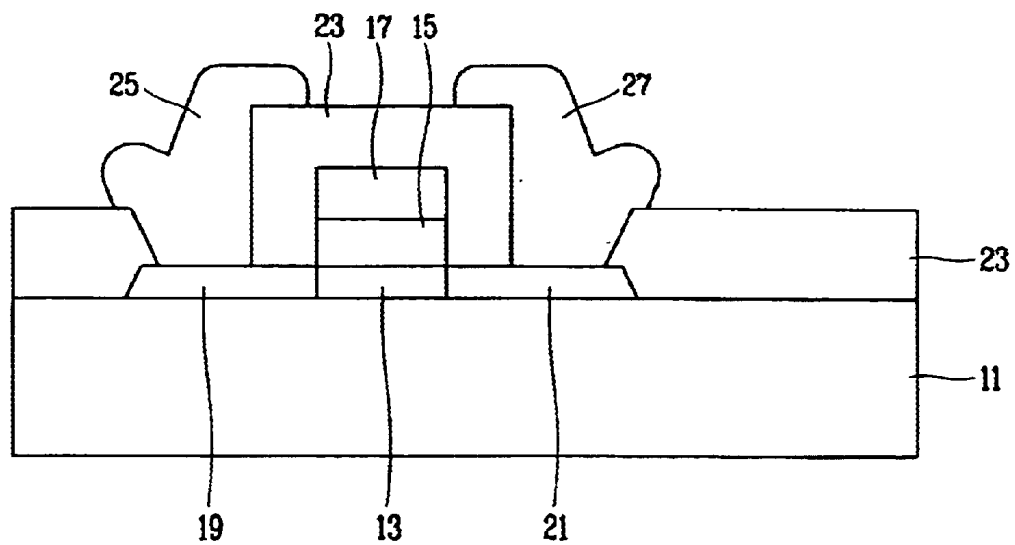

FIG. 1C
RELATED ART

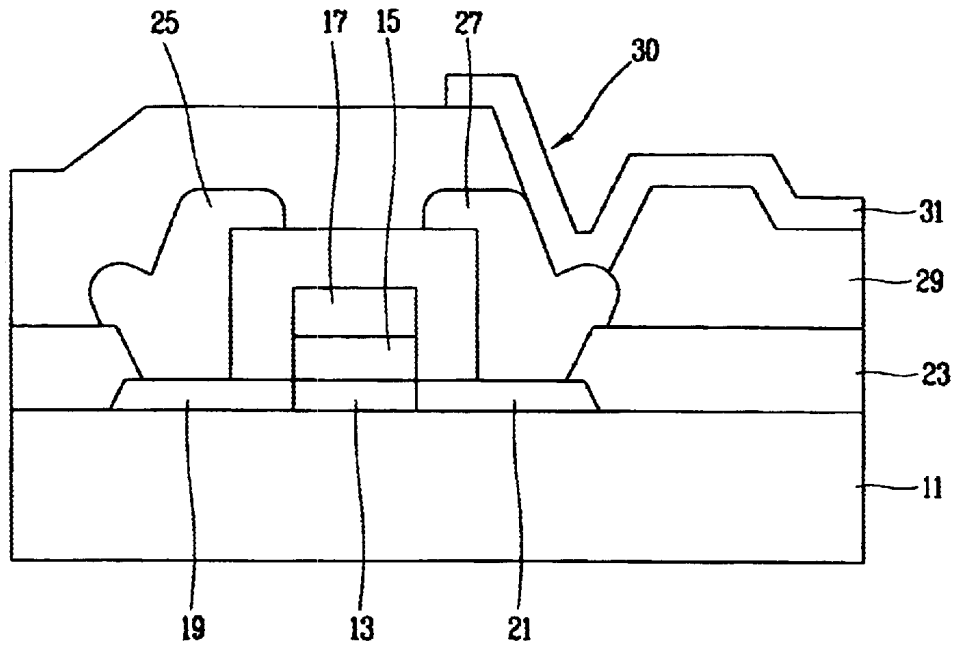

FIG. 1D
RELATED ART

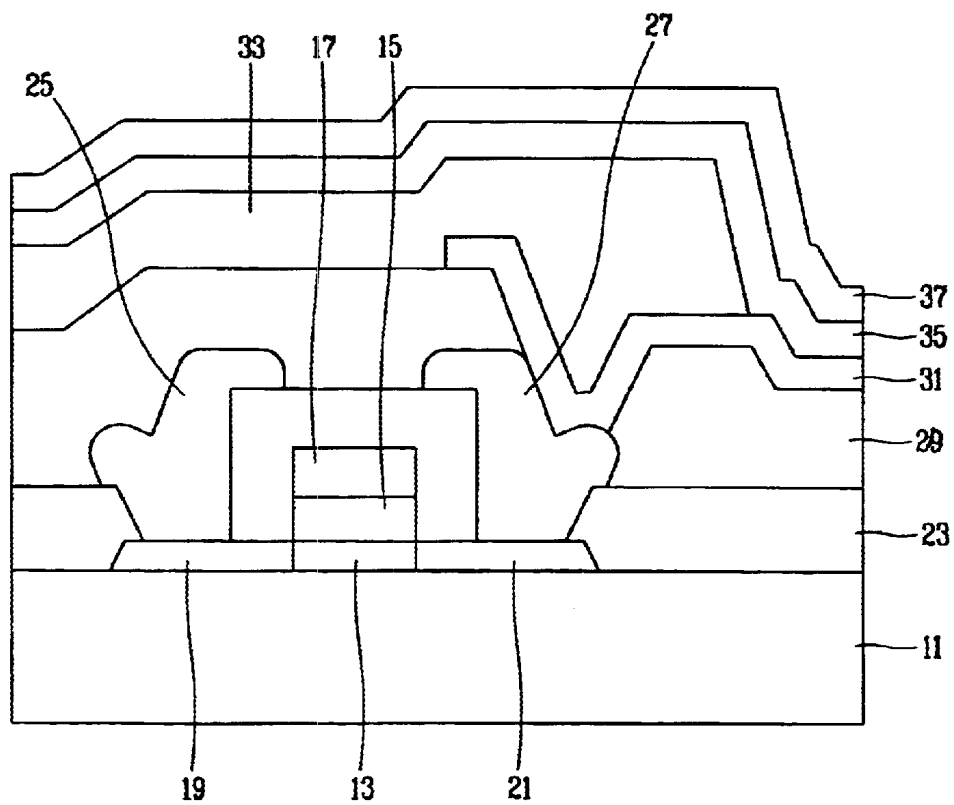

FIG. 2A

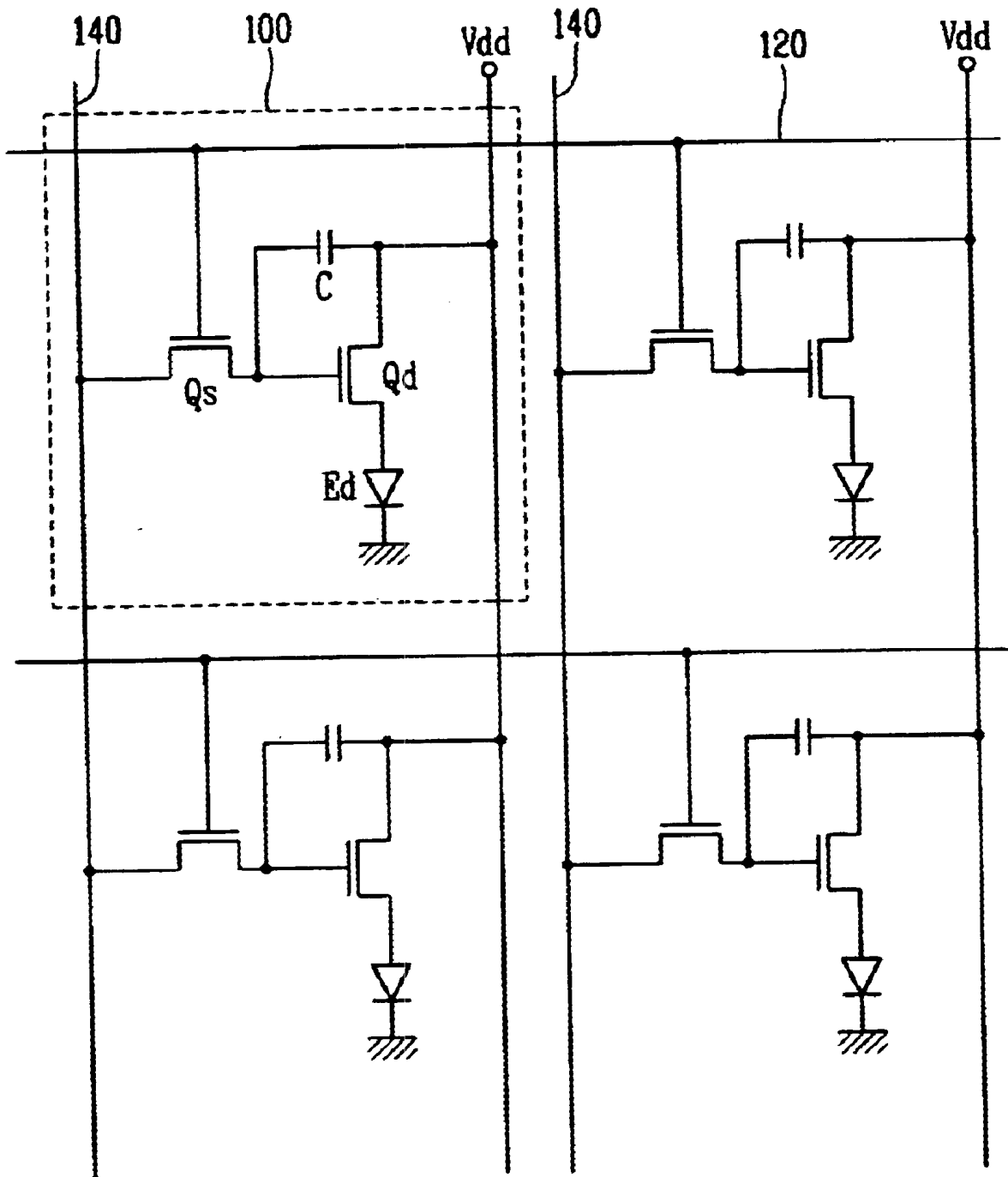

FIG. 2B

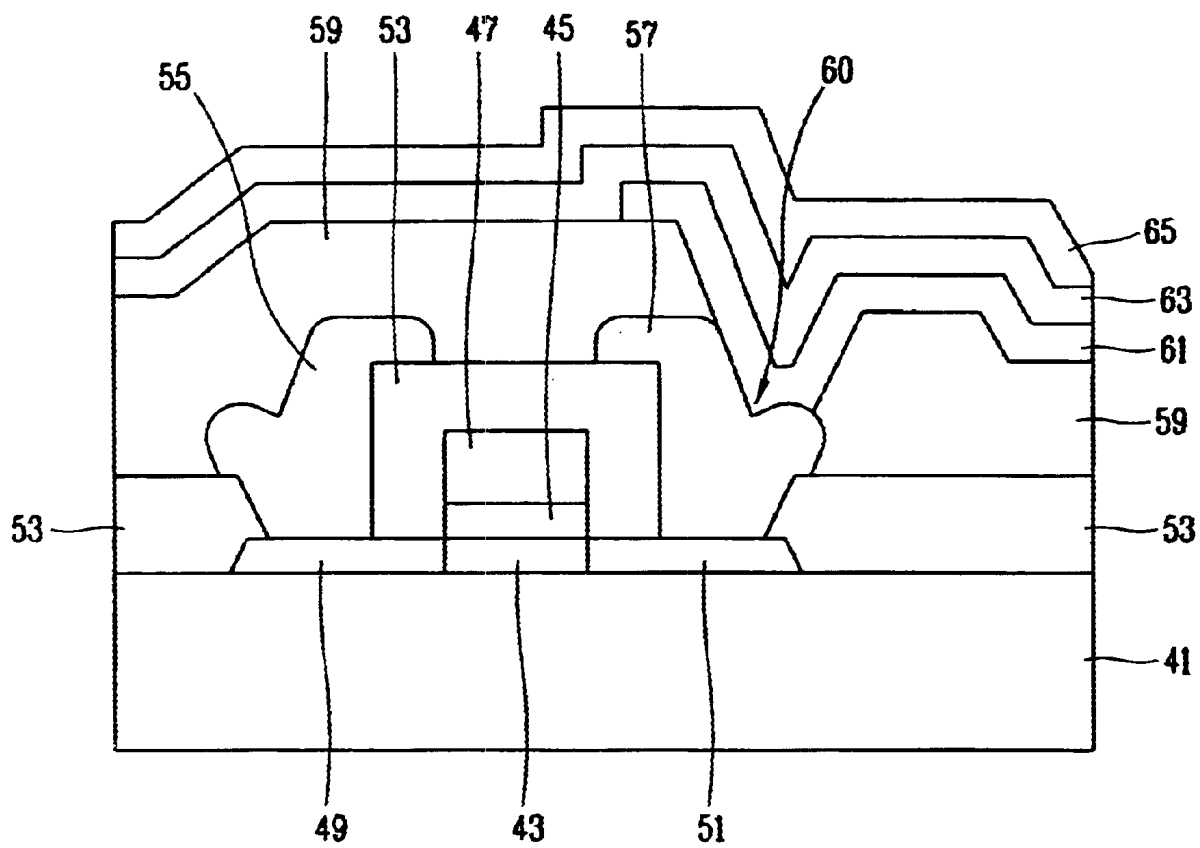

FIG. 3A

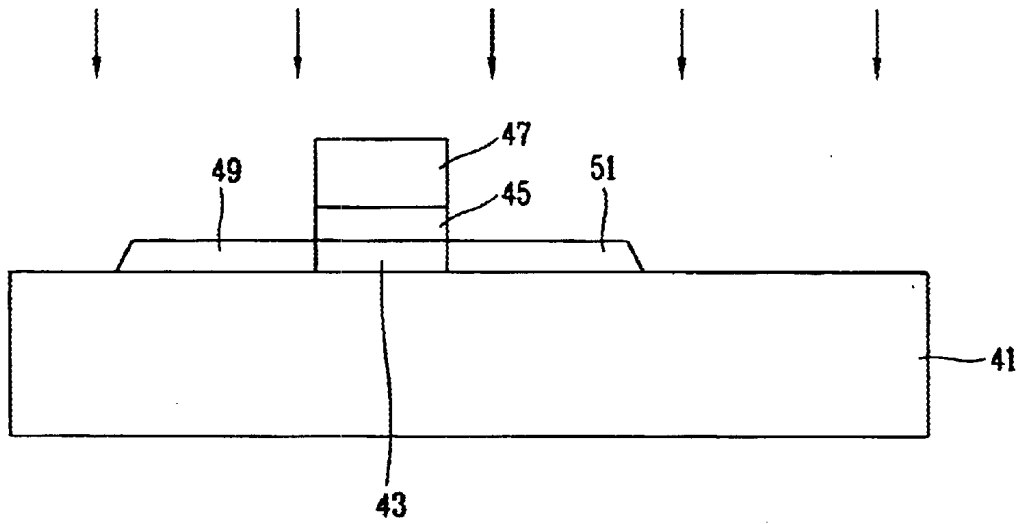

FIG. 3B

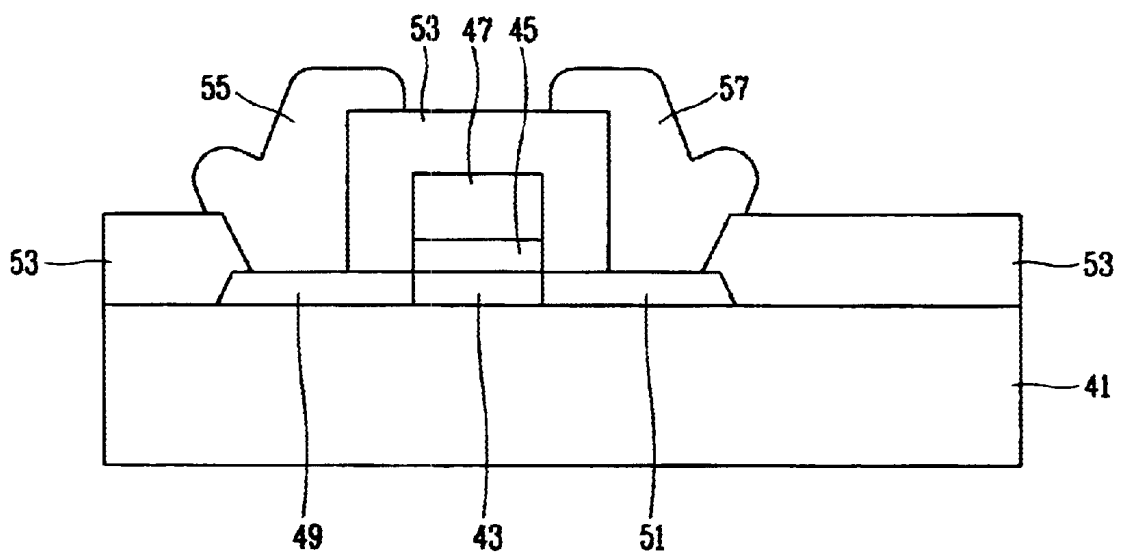

FIG. 3C

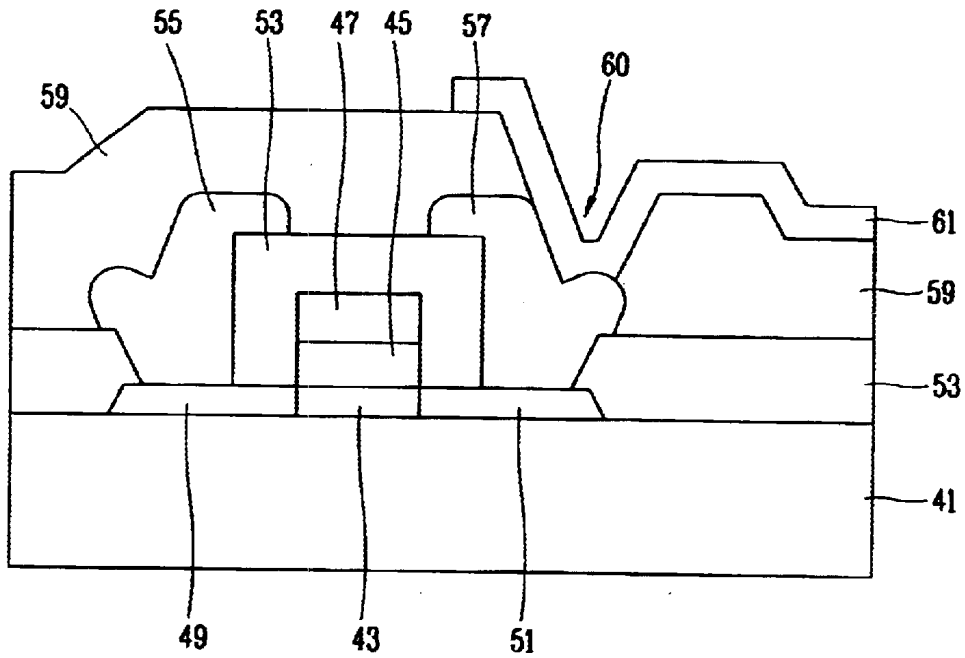
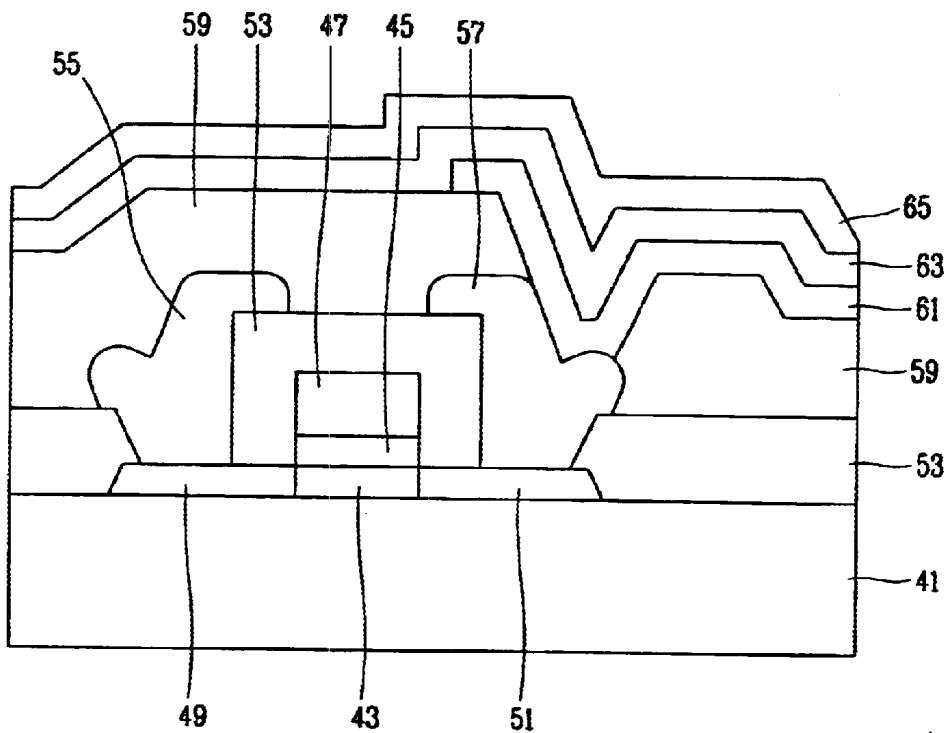

FIG. 3D



ELECTRO-LUMINESCENT DISPLAY AND A METHOD OF MANUFACTURING THE SAME

BACKGROUND OF THE INVENTION

1. Field of the Invention

The present invention relates to an electro-luminescent display (ELD) and a method of manufacturing thereof. More specifically, the present invention relates to an active ELD including an organic luminescent layer.

2. Discussion of the Related Art

An ELD is a luminescent device that emits light when electrons and holes that are injected into a luminescent layer recombine. The emission of light by the recombination of electrons and holes eliminates the need for a back-light in the ELD. Thus, it is easy to manufacture a very thin panel using an ELD. Further, the ELD has the added advantage of low power consumption. Additionally, an organic ELD, having a light-emitting layer with an organic electro-luminescent (EL) substance, is characterized by a low driving voltage, high light-emitting efficiency, and low process temperature. However, organic EL substances are vulnerable to moisture so that the patterns are defined by a method that prevents the organic EL substance from contacting moisture directly, unlike conventional photolithography.

In an active ELD, a plurality of pixels are defined by providing a plurality of scanning lines that cross with a plurality of signal lines, and also such that a power supply line is arranged in the same direction as the signal line in each of the pixels. Each pixel includes a storage capacitor, an EL portion, and at least one switching device such as a thin film transistor (TFT).

When the pixel includes two TFTs, an excitation signal for the EL portion is distinguished from the scanning signal. The EL portion is selected by a logic TFT which is the first TFT, and the excitation signal for the EL portion is controlled by the second TFT. The storage capacitor then maintains the excitation power in the EL portion of the selected cell.

FIGS. 1A to FIGS. 1D illustrate a method of manufacturing an ELD according to a related art method. Referring to FIG. 1A, polysilicon is deposited on an insulating substrate 11 having a switching part and a pixel part, via a chemical vapor deposition (CVD) process. Then an active layer 13 is formed by patterning the polysilicon via a photolithography process. An insulating substance such as silicon oxide, silicon nitride, or other similar substances are then deposited on the insulating substrate 11 to cover the active layer 13. Next, an electrically-conductive substance is deposited on the insulating substance. Then, a gate insulating layer 15 and a gate electrode 17 is formed by sequentially patterning the electrically-conductive substance and the insulating substance so that they remain on the middle portion of the active layer 13. Note that a scanning line (not shown in the drawing) that is connected to the gate electrode 17 may be provided as soon as the gate electrode 17 is formed. A source region 19 and a drain region 21 are then formed by heavily doping the exposed portions of the active layer 13 with either n type or p type impurities with the gate electrode 17 functioning as a mask. Note that the middle portion of the active layer 13, which is not doped with impurities, becomes a channel region.

Referring to FIG. 1B, a first insulating interlayer 23 is then provided and covers the active layer 13, the gate electrode 17, and the scanning line by depositing an insu-

lating substance such as silicon oxide, silicon nitride, or other similar substances on the insulating substrate 11. Next, the first insulating interlayer 23 is patterned to expose the source region 19 and the drain region 21, and a source electrode 25 and a drain electrode 27 are connected electrically with the exposed source region 19 and exposed drain region 21, respectively, by depositing and then patterning a known conductive substance. Thus, a TFT that functions as a switching device is manufactured. Note that a signal line (not shown in the drawing) may be defined on the insulating interlayer 23 at the same time the source electrode 25 and the drain electrode 27 are provided.

Referring to FIG. 1C, a second insulating interlayer 29 is provided and covers the source electrode 25 and the drain electrode 27 and the signal line by depositing silicon oxide or silicon nitride on the first insulating interlayer 23. A contact hole 30 exposes the drain electrode 27 and is provided by patterning the second insulating interlayer 29. Next, a transparent conductive substance is deposited so as to contact the exposed portion of the drain electrode 27 through the contact hole 30 that is provided in the second insulating interlayer 29. Then, an anode electrode 31 is formed by patterning via a photolithography process the transparent conductive substance so that the anode electrode 31 remains in the pixel portion of the second insulating interlayer 29. Note that the anode electrode 31 is electrically connected to the drain electrode 27, and is isolated electrically from other anode electrodes in adjacent pixel cells.

Referring to FIG. 1D, a passivation layer 33 covers the anode electrode 31 by the deposition of silicon oxide or silicon nitride on the second insulating interlayer 29. Alternatively, the passivation layer 33 may be formed with an organic substance such as BCB (benzocyclobutene), SOG (spin-on glass), and other similar substances. Note that the passivation layer 33 made of an organic substance may be relatively thick in order to provide an even surface. Next, the passivation layer 33 is patterned via a photolithography process, including a dry etching process, so as to expose the anode electrode 31. An organic EL layer 35, which emits a predetermined color such as red, blue, or green, is provided on the passivation layer 33 by an evaporation process. Note that the organic EL layer 35 just contacts the anode electrode 31 and the exposed pixel portion. Next, a cathode electrode 37, which functions as a common electrode, is disposed on the organic EL layer 35.

As mentioned in the above description, the ELD of the related art carries out the switching operation by selecting a TFT that has an n-type channel in a certain pixel, which has a predetermined signal line (not shown in the drawing) crossing with a predetermined scanning line (not shown in the drawing), such that a 'high' signal is applied to the predetermined scanning line while a 'high' signal is applied to the predetermined signal line. Thus, the selected TFT turns on and transfers the signal of the predetermined signal line to the drain electrode by which holes are injected into the organic EL layer via the anode electrode and electrons are injected into the organic EL layer via the cathode electrode. Thus, the pixel achieves light-emission through the recombination of electrons and holes.

Unfortunately, in the structure and method of the related art, the exposed portion of the anode electrode is easily damaged by the collision of the ions when dry-etching the passivation layer for exposing the anode electrode. Further, contaminant particles, albeit a small amount, remain on the exposed portion of the anode electrode after the etching process. Thus, the damage to the anode electrode caused by the collision of the ions during the etching process and the

remaining contaminant particles on the anode electrode after the etching process creates a barrier interface between the anode electrode and the EL layer that hinders the efficient transport of charge carriers such as holes. Therefore, the expected life span, brightness, and efficiency of the ELD suffers greatly from the structure and method of the related art.

SUMMARY OF THE INVENTION

To overcome the problems described above, preferred embodiments of the present invention provide an ELD and a method of manufacturing the ELD that improves the expected life span, brightness, and efficiency of the ELD by preventing the generation of a barrier interface between the anode electrode and the organic EL layer, which hinders the transport of charge carriers such as holes across the interface.

A preferred embodiment of the present invention includes a substrate having a pixel portion and a switching portion, an active layer on the switching portion of the substrate including a source region on a first end of the active layer, a drain region on a second end of the active layer, and a channel region at a middle portion of the active layer and in between the drain region and the source region, a gate insulating layer on the channel region, a gate electrode on the gate insulating layer such that the gate insulating layer is disposed between the gate electrode and the active layer, an insulating interlayer on the substrate covering the gate electrode, wherein the insulating interlayer does not substantially cover the source and drain regions so that substantial portions of the source and drain regions are exposed, a source electrode and a drain electrode in contact electrically with the exposed portions of the source and drain regions, respectively, a passivation layer on the insulating interlayer, wherein the passivation layer covers the source electrode and the drain electrode, a connect hole in the passivation layer, wherein the connect hole substantially exposes the drain electrode, an anode electrode on the passivation layer, wherein the anode electrode is in contact electrically with the drain electrode through the connect hole, an organic electro-luminescent layer on the passivation layer and covering the anode electrode, and a cathode electrode on the organic electro-luminescent layer.

Another preferred embodiment of the present invention includes a substrate, a plurality of layers on the substrate, wherein the plurality of layers includes source and drain electrodes, a passivation layer on the substrate and covering the source and drain electrodes, a connect hole in the passivation layer and exposing the drain electrode, an anode electrode on the passivation layer and in contact with the drain electrode, and an organic electro-luminescent layer on the passivation layer covering the anode electrode.

In another preferred embodiment of the present invention, a method of manufacturing an ELD includes the steps of providing a substrate, separating the substrate into a switching portion and a pixel portion, forming an active layer on the switching portion, forming a gate insulating layer and a gate electrode on a middle portion of the active layer, forming a source region and a drain region on exposed portions of the active layer by doping the exposed portions of the active layer heavily with impurities while using the gate electrode as a mask, disposing an insulating interlayer on the substrate and covering the active layer and the gate electrode, patterning the insulating interlayer so as to expose the source and drain regions, forming a source electrode and a drain electrode that is in contact with the exposed portions

of the source and drain regions, forming a passivation layer on the insulating interlayer, defining a contact hole in the passivation layer for exposing the drain electrode, defining an anode electrode on the passivation layer, and covering the drain electrode so as to be in contact with the drain electrode, forming an organic electro-luminescent layer on the passivation layer and covering the anode electrode, defining a cathode electrode on the organic electro-luminescent layer.

Therefore, preferred embodiments of the present invention provide an ELD structure and method of manufacturing an ELD which achieve the advantages of increasing the expected lifespan, increasing the brightness, and improving the efficiency of the ELD by preventing the generation of a barrier interface between the anode electrode and an electro-luminescence layer by eliminating a subsidiary layer between the anode electrode and the electro-luminescence layer thereby removing the need to etch the subsidiary layer for allowing the anode electrode and the electro-luminescence layer to have excellent contact therebetween.

Other features, elements and advantages of the present invention will be described in detail below with reference to preferred embodiments of the present invention and the attached drawings.

BRIEF DESCRIPTION OF THE ATTACHED DRAWINGS

The present invention will become more fully understood from the detailed description given herein below and the accompanying drawings which are given by way of illustration only, and thus do not limit the present invention and wherein:

FIGS. 1A to FIGS. 1D illustrate a method of manufacturing an ELD according to a related art;

FIG. 2A is a general diagram of an ELD according to a preferred embodiment of the invention;

FIG. 2B is a cross-sectional view of a portion of an ELD according to a preferred embodiment of the present invention; and

FIG. 2A is a general diagram of an ELD and FIG. 2B is a cross-sectional view of an ELD according to a preferred embodiment of the present invention. As shown in FIG. 2A, the ELD includes a plurality of pixels each pixel including: a switching TFT (Qs) having a gate electrode connected to a gate line 120 and a source electrode connected to a data line 140; a driving TFT (Qd) having a gate electrode connected to a drain of the switching TFT, a source electrode connected to a power line Vdd, and a drain electrode connected to an electro-luminescent diode Ed; and a capacitor C connected between the gate electrode and the source electrode of the driving TFT.

Referring to FIG. 2B, each pixel of the ELD according to the present invention includes an active layer 43 preferably made of polysilicon and preferably having a thickness of about 500 Å to about 1000 Å disposed on a predetermined portion of a switching portion of an insulating substrate 41 made of a transparent substance such as quartz, glass, or other similar substance, and having a switching portion and a pixel portion. A source region 49 and a drain region 51, which are doped heavily with either n-type impurities such as P or, As, or p-type impurities such as B, are provided at both ends of the active layer 43. The approximate central portion of the active layer 43 is not doped with impurities and defines a channel region. A gate insulating layer 45, which is preferably made of an insulating substance such as silicon oxide, silicon nitride and other similar substances and preferably about 800 Å to 1500 Å thick, is provided on

the channel region of the active layer **43**. A gate electrode **47**, which is made of an electrically-conductive substance such as Al, Al alloy or other similar substances having a low resistance and preferably about 4000 Å to 5000 Å thick, is provided on the gate insulating layer **45**.

FIG. **3A** to FIG. **3D** illustrate a method of manufacturing an ELD according to another preferred embodiment of the present invention.

DETAILED DESCRIPTION OF PREFERRED EMBODIMENTS

FIG. **2** is a cross-sectional view of an ELD according to a preferred embodiment of the present invention. Referring to FIG. **2**, an ELD includes an active layer **43** preferably made of polysilicon and preferably having a thickness of about 500 Å to about 1000 Å disposed on a predetermined portion of a switching portion of an insulating substrate **41** made of a transparent substance such as quartz, glass, or other similar substance, and having a switching portion and a pixel portion. A source region **49** and a drain region **51**, which are doped heavily with either n-type impurities such as P or, As, or p-type impurities such as B, are provided at both ends of the active layer **43**. The approximate central portion of the active layer **43** is not doped with impurities and defines a channel region. A gate insulating layer **45**, which is preferably made of an insulating substance such as silicon oxide, silicon nitride and other similar substances and preferably about 800 Å to 1500 Å thick, is provided on the channel region of the active layer **43**. A gate electrode **47**, which is made of an electrically-conductive substance such as Al, Al alloy or other similar substances having a low resistance and preferably about 4000 Å to 5000 Å thick, is provided on the gate insulating layer **45**.

In the present preferred embodiment, the gate electrode **47** may have two layers such that a refractory metal such as Cr, Mo, Ti, Ta, or other similar metals are deposited on a low resistance metal such as Al, Al alloy or other similar metals. Also, the gate electrode **47** may be formed as soon as a scanning line (not shown in the drawing), which is connected to the gate electrode **47**, is provided.

Next, an insulating interlayer **53** that exposes the source region **49** and the drain region **51** are defined on the insulating substrate **41** and covers the gate electrode **47**. The insulating interlayer **53** which is preferably about 4000 Å to 5000 Å thick is defined preferably by depositing an insulator such as silicon oxide, silicon nitride and other similar substances. Then, a source electrode **55** and a drain electrode **57**, which are preferably in contact electrically with the exposed portions of the source region **49** and the drain regions **51**, respectively, are provided on the insulating interlayer **53**. The source electrode **55** and the drain electrode **57** are preferably made of a single layer of conductive metal such as Al, Al alloy, or other similar substances having a low resistance. Note that a signal line (not shown in the drawing) that is connected to the source electrode **55** may be formed on the insulating interlayer **53** at the same time that the source electrode **55** is formed. A passivation layer **59** that covers the source electrode **55** and the signal line, but which exposes the drain electrode **57** through a hole **60**, is provided on the insulating interlayer **53**. The passivation layer **59** is provided preferably by depositing silicon oxide or silicon nitride and having a thickness preferably about 4000 Å to about 5000 Å, and then coating the deposited silicon oxide or silicon nitride with an organic substance such as BCB (Benzocyclobutene), SOG (Spin On Glass), or other similar substances, wherein the coating is preferably about 1 μm to

3 μm thick. Note that in preferred embodiments of the present invention, the degradation from steps in the layers is less since the passivation layer **59** is relatively thick and includes the organic substance to provide a smooth surface thereon.

Next, an anode electrode **61** that is in contact electrically with the exposed portion of the drain electrode **57** through the hole **60** is provided on the passivation layer **59** of the pixel portion. Note that the anode electrode **61**, which is defined preferably by depositing a transparent conductive substance such as an ITO (Indium Tin Oxide), TO (Tin Oxide), or other similar substances and is preferably about 1000 to 2000 Å thick, is isolated electrically from the other anode electrodes in the neighboring pixels. An organic EL layer **63** is then provided on the passivation layer **59** and preferably covers the anode electrode **61**. Note that the organic EL layer **63** is preferably about 1000 to 2000 Å thick, and is defined by depositing a substance that emits a light having a red, blue, or green color as electrons and holes recombine. Then, a cathode electrode **65**, which is preferably used as a common electrode connected to ground, is defined on the organic EL layer **63**. The cathode electrode **65** is defined preferably by depositing a metal having a low work function, such as Al, Al alloy, Ka, Na, Ca, Li, or other similar substances, to make it easy for electrons to be injected into the organic EL layer **63**, and is preferably about 1000 Å to about 3000 Å thick. Note that the organic EL layer **63** also includes a hole injecting and transporting region that is in contact with the anode electrode **61**, and an electron injecting and transporting region that is in contact with the cathode electrode **65**, and a luminescent layer that emits light. The hole or electron injecting/transporting regions may be provided with a single substance or with multiple substances. The light emission occurs in the hole and electron injecting/transporting region as the transported electrons and holes recombine in the luminescent layer.

Note that in preferred embodiments of the present invention, the organic EL layer **63** is defined on the entire anode electrode **61** and is in contact with the entire anode electrode without a subsidiary layer (e.g., layer **33** in FIG. **1**) located in between. Therefore, the surface of the anode electrode **61** is not damaged since an etching process is not necessary for the organic EL layer **63** to contact the anode electrode **61**. Further, the etch remainders or the contaminant particles that are contained in etchant do not exist on the anode electrode **61**.

Therefore, the expected life span, brightness, and efficiency of the ELD is improved dramatically as charge carriers such as holes are transported with ease at the interface between the anode electrode **61** and the organic EL layer **63**.

FIG. **3A** to FIG. **3D** illustrate a method of manufacturing an ELD according to a preferred embodiment of the present invention. Referring to FIG. **3A**, an active layer **43** is provided preferably by depositing a polysilicon layer preferably about 500 Å to 1000 Å thick on an insulating substrate **41** having a switching portion and a pixel portion preferably via a CVD process and then patterning the polysilicon layer preferably via a photolithography process. The insulating substrate **41** is preferably made of a transparent substance such as quartz, glass, or other similar substances. An insulating substance preferably about 800 Å to 1500 Å thick such as silicon oxide, silicon nitride, and other similar substances is deposited on the insulating substrate **41** preferably via a CVD process and preferably covers the active layer **43**. Next, a conductive metal preferably about 4000 Å to 5000 Å thick, and preferably having

low resistivity, such as Al, Al alloy, or other similar metals is deposited on the insulating substance preferably via a sputtering method. Next, a gate electrode 47 and a gate insulating layer 45 are then provided by patterning, preferably via a photolithography process, the conductive metal and the insulating substance so that they remain on the middle portion of the active layer 43. In the above-described method, the gate electrode 47 may preferably have two layers such that a refractory metal, which is made of Cr, Mo, Ti, Ta, or other similar substances, is disposed preferably on a low resistance metal such as Al, Al alloy or other similar substances. Note that the gate electrode 47 may be provided as soon as a scanning line (not shown in the drawing) that is connected to the gate electrode 47 is formed. A source region 49 and a drain region 51, both of which are preferably doped heavily with either n-type impurities such as P, As, or p-type impurities such as B, are defined preferably at the two exposed ends of the active layer 43. The middle portion of the active layer 43, which is not doped with impurities, defines a channel region of the active layer 43.

Referring to FIG. 3B, an insulating interlayer 53 is provided on the insulating substrate 41 and preferably covers the gate electrode 47, the active layer 43, and the scanning line by dispersing an insulating substance preferably about 4000 Å to 5000 Å thick such as silicon oxide, silicon nitride and other similar substances. The insulating interlayer 53 is then preferably patterned so as to expose the source region 49 and the drain region 51. Next, a source electrode 55 and a drain electrode 57, which are in contact electrically with the exposed portions of the source region 49 and the drain region 51, respectively, are defined on the insulating interlayer 53. The source electrode 55 and the drain electrode 57 are formed preferably by depositing and then patterning the conductive metal having a low resistance such as Al, Al alloy, or other similar substances preferably via a sputtering method and then preferably via a photolithography process, respectively. The resultant structure is a thin film transistor that functions as a switching device. Note that the source electrode 55 and the drain electrode 57 are preferably made from a single layer of a conductive metal such as Al, Al alloy, or other similar substances having a low resistance. Also, a signal line (not shown in the drawing) is connected to the source electrode 55, and may be defined on the insulating interlayer 53 at the same time as the source electrode 55 and the drain electrode 57 are formed.

FIGS. 3A to FIGS. 3D illustrate a method of manufacturing an ELD having the configuration as shown in FIG. 2 according to a preferred embodiment of the present invention. Referring to FIG. 3A, an active layer 43 is provided preferably by depositing a polysilicon layer preferably having a thickness of about 500 Å to about 1000 Å on an insulating substrate 41 having a switching portion and a pixel portion preferably via a CVD process and then patterning the polysilicon layer preferably via a photolithography process. The insulating substrate 41 is preferably made of a transparent substance such as quartz, glass, or other similar substances. An insulating substance, preferably having a thickness of about 800 Å to about 1500 Å, such as silicon oxide, silicon nitride, and other similar substances is deposited on the insulating substrate 41 preferably via a CVD process and preferably covers the active layer 43. Next, a conductive metal preferably having a thickness of about 4000 Å to about 5000 Å, and preferably having low resistivity, such as Al, Al alloy, or other similar metals is deposited on the insulating substance preferably via a sputtering method. Next, a gate electrode 47 and a gate insulating layer 45 are then provided by patterning, preferably via

a photolithography process, the conductive metal and the insulating substance so that they remain on a portion (e.g., middle portion) of the active layer 43. In the above-described method, the gate electrode 47 may preferably have two layers such that a refractory metal, which is made of Cr, Mo, Ti, Ta, or other similar substances, is disposed preferably on a low resistance metal such as Al, Al alloy or other similar substances. Note that the gate electrode 47 may be provided as soon as a scanning line (not shown in the drawing) that is connected to the gate electrode 47 is formed. A source region 49 and a drain region 51, both of which are preferably doped heavily with either n-type impurities such as P, As, or p-type impurities such as B, are defined preferably at the two exposed ends of the active layer 43. The middle portion of the active layer 43, which is not doped with impurities, defines a channel region of the active layer 43.

Referring to FIG. 3D, an organic EL layer 63 is provided and preferably covers the anode electrode 61. Next, a cathode electrode 65, which functions as a common electrode, is provided on the organic EL layer 63. The cathode electrode 65 is preferably about 1000 Å to 3000 Å thick, and is provided by depositing a metal with a low work function such as Al, Al alloy, Ka, Na, Ca, Li, or other similar metals for easier injection of electrons into the organic EL layer 63. The organic EL layer 63 is preferably about 1000 Å to 2000 Å thick, and is provided by depositing a substance that emits light as electrons and holes recombine, the light being either red, blue, or green. The organic EL layer 63 preferably includes a hole injecting and transporting region that is in contact with the anode electrode 61, an electron injecting and transporting region that is in contact with the cathode electrode 65, and a luminescent layer that emits light. Note that the hole and electron injecting/transporting regions may be defined with a single substance or with multiple substances. Light-emission occurs in the hole and electron injecting/transporting regions as the transported electrons and holes recombine in the luminescent layer.

Note that in the ELD of preferred embodiments of the present invention, the organic EL layer 63 is provided on the anode electrode 61 and in contact with the anode electrode without a subsidiary layer disposed in between. Thus, the surface of the anode electrode 61 is not damaged because an etching step is not performed to allow the organic EL layer 63 to be in contact with the anode electrode 61. Further, etch remainders or contaminant particles contained in the etch gases do not accumulate on the surface of the anode electrode 61. Accordingly, there does not exist a barrier interface between the anode electrode and organic EL layer which would hinder the transport of carriers such as holes. Therefore, the expected life span, the brightness, and the efficiency of the ELD are greatly improved as the holes are transported through the interface between the anode electrode and organic EL layer with ease.

While the invention has been particularly shown and described with reference to preferred embodiments thereof, it will be understood by those skilled in the art that the foregoing and other changes in form and details may be made therein without departing from the spirit and scope of the present invention.

What is claimed is:

1. An electro-luminescent display comprising a substrate including a plurality of pixels, each of said pixels including:
 - a switching TFT having a gate electrode connected to a gate line and a source electrode connected to a data line;
 - a driving TFT having a gate electrode connected to a drain of the switching TFT, a source electrode connected to

9

- a power line, and a drain electrode connected to an electro-luminescent diode;
- a capacitor connected between said gate electrode and said source electrode of the driving TFT;
- an active layer of the driving TFT including a source region on a first side end of the active layer, a drain region on a second end of the active layer, and a channel region at an approximate middle portion of the active layer and in between the drain region and the source region;
- a gate insulating layer on the channel region and said gate electrode on the gate insulating layer such that the gate insulating layer is disposed between the gate electrode and the active layer;
- an insulating layer on the substrate including the gate electrode, wherein the insulating interlayer does not substantially cover the source and drain regions so that substantial portions of the source and drain regions are exposed and said source electrode and said drain electrode are in contact electrically with the exposed portions of the source and drain regions, respectively;
- a passivation layer on the insulating interlayer and arranged to cover the source electrode and the drain electrode;
- a connect hole in the passivation layer and arranged to expose the drain electrode;
- an anode electrode on the passivation layer and arranged to electrically contact the drain electrode through the hole;
- an organic electro-luminescent layer of said electro-luminescent diode on portions of the passivation layer and covering the anode electrode; and
- a cathode electrode on the organic electro-luminescent layer.
2. The display according to claim 1, wherein the active layer is about 500 Å to 1000 Å thick, and is formed with polysilicon.
3. The display according to claim 1, wherein the passivation layer is about 4000 Å to 5000 Å thick, and is made of an inorganic substance such as silicon oxide or silicon nitride.
4. The display according to claim 1, wherein the passivation layer is made of an organic substance including one of benzocyclobutene and Spin On Glass having a thickness of about 1 μm to about 3 μm.
5. The display according to claim 1, wherein the organic electro-luminescent layer is about 1000 Å to about 2000 Å thick.
6. The display according to claim 1, wherein the organic electro-luminescent layer includes a hole injecting/transporting region in contact with the anode electrode, an electron injecting/transporting region in contact with the cathode electrode, and a luminescent layer for emitting light.
7. The display according to claim 6, wherein the hole and electron injecting/transporting regions are made of a single substance.
8. The display according to claim 6, wherein the hole and electron injecting/transporting regions are made of multiple substances.
9. An electro-luminescent display comprising:
- a substrate;
 - a plurality of layers on the substrate, wherein the plurality of layers include source and drain electrodes;
 - a passivation layer on the substrate and covering the source and drain electrodes;

10

- a connect hole in the passivation layer and exposing the drain electrode;
 - an anode electrode on the passivation layer and in contact with the drain electrode;
 - an organic electro-luminescent layer in contact with portions of the passivation layer and covering the anode electrode; and
 - a cathode electrode on the organic electro-luminescent layer.
10. The display according to claim 9, wherein the plurality of layers further comprises:
- an active layer on the substrate including a source region on a first end of the active layer, a drain region on a second end of the active layer, and a channel region at an approximate middle portion of the active layer and in between the drain region and the source region;
 - a gate insulating layer on the channel region;
 - a gate electrode on substantially the channel region such that the gate insulating layer is disposed between the gate electrode and the active layer;
 - an insulating interlayer on the substrate including the gate electrode, wherein the insulating interlayer does not substantially cover the source and drain regions so that substantial portions of the source and drain regions are exposed; and
 - the source and drain electrodes in contact electrically with the exposed portions of the source and drain regions, respectively.
11. The display according to claim 9, wherein the passivation layer is about 4000 Å to 5000 Å thick, and is made of an inorganic substance such as silicon oxide and silicon nitride.
12. The display according to claim 9, wherein the passivation layer includes an organic substance including one of benzocyclobutene and Spin On Glass having a thickness of about 1 μm to about 3 μm thick.
13. The display according to claim 9, wherein the electro-luminescent layer is about 1000 Å to 2000 Å thick.
14. The display according to claim 9, wherein the organic electro-luminescent layer includes a hole injecting/transporting region in contact with the anode electrode, an electron injecting/transporting region in contact with the cathode electrode, and a luminescent layer for emitting light.
15. The display according to claim 1, wherein the organic electro-luminescent layer covers the source electrode, the gate electrode and the drain electrode of the driving TFT.
16. The display according to claim 9, wherein the organic electro-luminescent layer covers the source electrode, a gate electrode and the drain electrode of the driving TFT.
17. The display according to claim 1, wherein the organic electro-luminescent layer contacts portions of the passivation layer and the anode electrode.
18. The display according to claim 9, wherein the organic electro-luminescent layer contacts portions of the passivation layer and the anode electrode.
19. An electro-luminescent display comprising:
- a substrate;
 - a plurality of layers on the substrate, wherein the plurality of layers include source and drain electrodes;
 - a passivation layer on the substrate and covering the source and drain electrodes;
 - a connect hole in the passivation layer and exposing the drain electrode;
 - an anode electrode on the passivation layer and in contact with the drain electrode;

11

an organic electro-luminescent layer on portions of the passivation layer and covering the anode electrode; and a cathode electrode on the organic electrode-luminescent layer,

wherein the organic electro-luminescent layer contacts portions of the passivation layer and the anode electrode.

20. The display according to claim 19, wherein the plurality of layers further comprises:

- an active layer on the substrate including a source region on a first end of the active layer, a drain region on a second end of the active layer, and a channel region at an approximate middle portion of the active layer and in between the drain region and the source region;
- a gate insulating layer on the channel region;
- a gate electrode on substantially the channel region such that the gate insulating layer is disposed between the gate electrode and the active layer;
- an insulating interlayer on the substrate including the gate electrode, wherein the insulating interlayer does not substantially cover the source and drain regions so that substantial portions of the source and drain regions are exposed; and

the source and drain electrodes in contact electrically with the exposed portions of the source and drain regions, respectively.

21. The display according to claim 19, wherein the passivation layer is about 4000 Å to 5000 Å thick, and is made of an inorganic substance such as silicon oxide and silicon nitride.

22. The display according to claim 19, wherein the passivation layer includes an organic substance including one of benzocyclobutene and Spin On Glass having a thickness of about 1 μm to about 3 μm thick.

12

23. The display according to claim 19, wherein the electro-luminescent layer is about 1000 Å to 2000 Å thick.

24. The display according to claim 19, wherein the organic electro-luminescent layer includes a hole injecting/transporting region in contact with the anode electrode, an electron injecting/transporting region in contact with the cathode electrode, and a luminescent layer for emitting light.

25. An electro-luminescent display comprising:

- a substrate;
- a plurality of layers on the substrate, wherein the plurality of layers include gate, source and drain electrodes of a driving TFT;
- a passivation layer on the substrate and covering the source and drain electrodes;
- a connect hole in the passivation layer and exposing the drain electrode;
- an anode electrode on the passivation layer and in contact with the drain electrode, the anode electrode covering only a portion of the driving TFT; and
- an organic electro-luminescent layer on portions of the passivation layer and covering the anode electrode, wherein the organic electro-luminescent layer covers the source electrode, the gate electrode and the drain electrode of the driving TFT.

26. The display according to claim 9, wherein at least one of the following is provided:

- the passivation layer is about 4000 Å to 5000 Å thick; and
- the organic electrode-luminescent layer is about 1000 Å to about 2000 Å thick.

27. The display according to claim 25, further comprising:

- a cathode electrode on the organic electro-luminescent layer.

* * * * *

专利名称(译)	电致发光显示器及其制造方法		
公开(公告)号	US6617608	公开(公告)日	2003-09-09
申请号	US09/550411	申请日	2000-04-17
[标]申请(专利权)人(译)	BAE盛骏 PARK容		
申请(专利权)人(译)	BAE晟准 朴勇		
当前申请(专利权)人(译)	LG.飞利浦液晶CO., LTD.		
[标]发明人	BAE SUNG JOON PARK JAE YONG		
发明人	BAE, SUNG-JOON PARK, JAE-YONG		
IPC分类号	H01L27/28 H01L29/417 H01L29/40 H01L27/32 H01J1/30 H01L35/24		
CPC分类号	H01L27/3244 H01L29/41733 H01L2251/558		
审查员(译)	LEE, EDDIE		
助理审查员(译)	LEE, EUGENE		
优先权	1019990019286 1999-05-27 KR		
其他公开文献	US20030062523A1		
外部链接	Espacenet USPTO		

摘要(译)

电致发光显示器及其制造方法通过将电致发光层直接放置在阳极电极上来防止在阳极电极和电致发光层之间形成阻挡界面，从而不需要蚀刻辅助电极这样，电致发光层和阳极电极具有良好的电接触。消除该蚀刻步骤防止了在蚀刻过程中由离子与阳极电极碰撞引起的对阳极电极的损坏。此外，防止蚀刻剂气体中存在的蚀刻残留物或污染物颗粒积聚在阳极电极上。因此，阳极的电荷载体易于通过阳极电极和电致发光层之间的界面传输，从而大大改善电致发光显示器的预期寿命，亮度和效率。

